

# ALUMINIUM SPRING HOOK CONE SHAPE WITH SAFETY SCREW

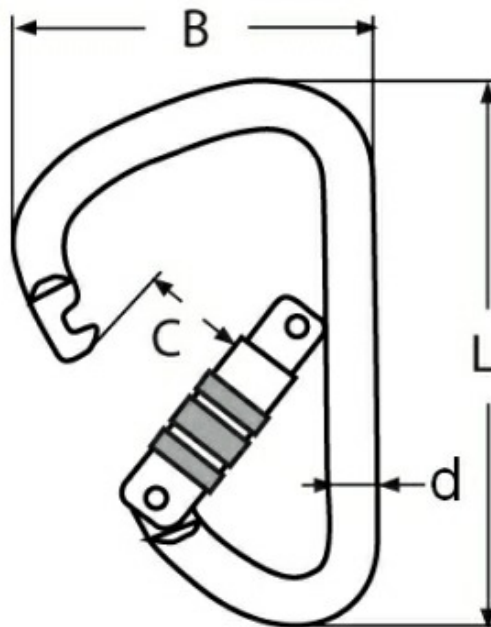

Size <i>d</i>	Code	<i>L</i>	<i>B</i>	<i>C</i>	<i>BL/Kg</i>
12	SKU50005	116.5	74.5	22	2400

Notes : Dimensions are a guide and may vary slightly. Pls check with us for dimension critical applications.  
 If Break (BL), Safe working load (SWL) or Working load limit (WLL) are shown:  
 This is a guide only. (Do not use for lifting unless it is a certified lifting product)

## ALUMINIUM SPRING HOOK CONE SHAPE WITH SAFETY SCREW

These Snaphooks or carabiners are lightweight and coloured and will not corrode due to their material Aluminium.

MATERIAL TYPE	ALUMINIUM
NOTES	NOT TO BE USED FOR LIFTING PURPOSES

## ADVANTAGES

- Cheaper than stainless
- Good for outdoor use
- Highly durable
- Corrosion resistant due to it being anodised