

BLACK COATED QUICK LINK

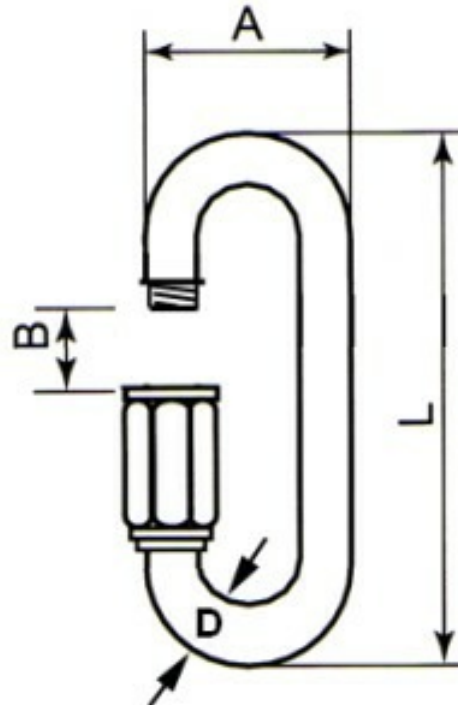

| Size (D) | A | B | D | L |
|----------|----|-----|---|----|
| 5 | 23 | 7.5 | 5 | 50 |
| 6 | 26 | 7.5 | 6 | 58 |
| 8 | 34 | 10 | 8 | 74 |

Notes : Dimensions are a guide and may vary slightly. Pls check with us for dimension critical applications.

If Break (BL), Safe working load (SWL) or Working load limit (WLL) are shown:
This is a guide only. (Do not use for lifting unless it is a certified lifting product)

BLACK COATED QUICK LINK

Quick Links can be used as chain connectors, repair links, fixed climbing points and net fixings. They are equally useful in many other applications. They are preferred over snap hooks in multi-directional load situations. This black coated variety can be used in areas where light reflection is to be kept to a minimum such as theatre or military applications.

| | |
|----------------------|--|
| MATERIAL TYPE | ZINC / BLACK COATED |
| FINISH | POLISHED |
| NOTES | NOT TO BE USED FOR LIFTING PURPOSES |

ADVANTAGES

- Black coated for no light reflection
- Aesthetically pleasing because they're designed to look like chain links.
- High Durability
- Reusable