

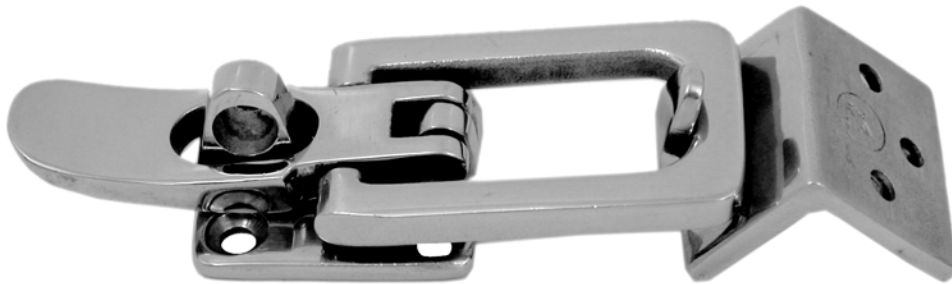

STEEL GEAR

Swivel hasp / latch - Lockable



Lockable swivel hasp with 90 degree catch

These latches are investment cast and polished, made from marine grade stainless. They have the same body as the other swivel hasp we sell, with the addition of a catch that can be mounted onto a 90 degree face. They can be used anywhere that requires a latch such as a gate or a door. The hole is designed to take a padlock of 6mm or less bar thickness

MATERIAL	
MATERIAL TYPE	Stainless 316 marine grade
FINISH	Polished / Shiny

ADVANTAGES

- Sturdy construction
- Will not rust
- Strong fixing points

DATASHEET

www.steelgear.co.uk

info@steelgear.co.uk

SPECIFICATION :

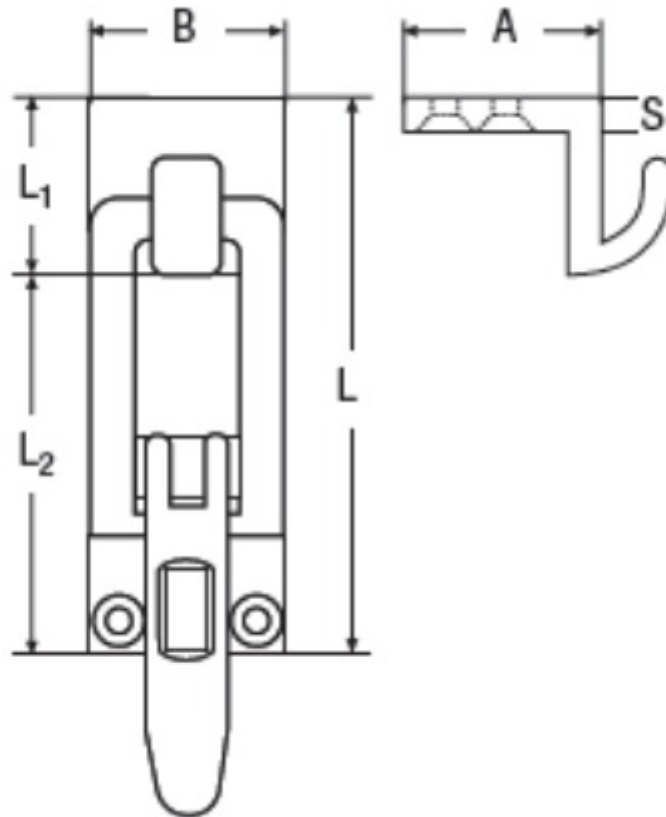

Code	L	L1	L2	B	A	S	Weight (g)
LAT1-90D-A4	62	20	42	28	23	3	100